

## HTM208 explosion-proof temperature transmitter



Nanjing Hangjia Electronic Technology Co., Ltd.

## Product Overview

HTM208 explosion-proof digital temperature transmitter uses PT100 or thermocouples as the signal measurement component. Highly reliable integrated circuit, specially developed for 4-20mA temperature transmitter, on-site display, simultaneous output of 4-20mADC, supports RS485 communication or HART communication and other remote signal transmission

The entire product has undergone rigorous testing and aging of components, semi-finished products and finished products. With its excellent reliability, wide adaptability, product flexibility and diversity, this product is widely used in on-site temperature measurement and control of industrial processes such as petroleum, chemical industry, metallurgy, electric power, hydrology, etc.

## Features

- ◆ Electronic housing is made of aluminum alloy, and the housing protection level is IP66
- ◆ Reverse polarity protection and instantaneous overcurrent and overvoltage protection measures, strong anti-interference, and good long-term stability
- ◆ High precision and good stability
- ◆ Reliable circuit and fast response speed

## Technical Parameters

Measuring Temperature Range	-196...0~100...1500℃
Measuring Medium	various liquid, gas, or steam compatible with 304 or 316L stainless steel
Sensor	PT100, thermocouple, etc.
Accuracy	± 0.5%FS
Long-term Stability	± 0.2%FS/year
Insertion Depth	customization
Installment Thread	customization
Operation Temperature	-40~85℃ (Normal model); -40~60℃ (Explosion-proof model)
Storage Temperature	-40~85℃
Supply Voltage	DC12~28V (Normal model). DC12~26V (Explosion-proof model)
Output Signal	2-wire 4~20mADC, or RS485, switch signal etc
Allowable load resistance	0~600 Ω (DC 24V, including cable resistance)
Protection Grade	IP65
Electrical Connection	Cables with cable gland
Working environment humidity	no more than 90% (+25℃)
Working altitude	no more than 2000m
Working atmospheric pressure	86~106Kpa

Explosion-proof

Ex db IIC T6 Gb

Ex tb IIIC T80°C Db

- Zone 1 and Zone 2 locations where explosive mixtures of Class IIA, IIB, IIC, and Group T1 to T6 combustible gases, steam, and air exist
- In an environment with explosive dust

## Structure Drawings (Unit: mm)

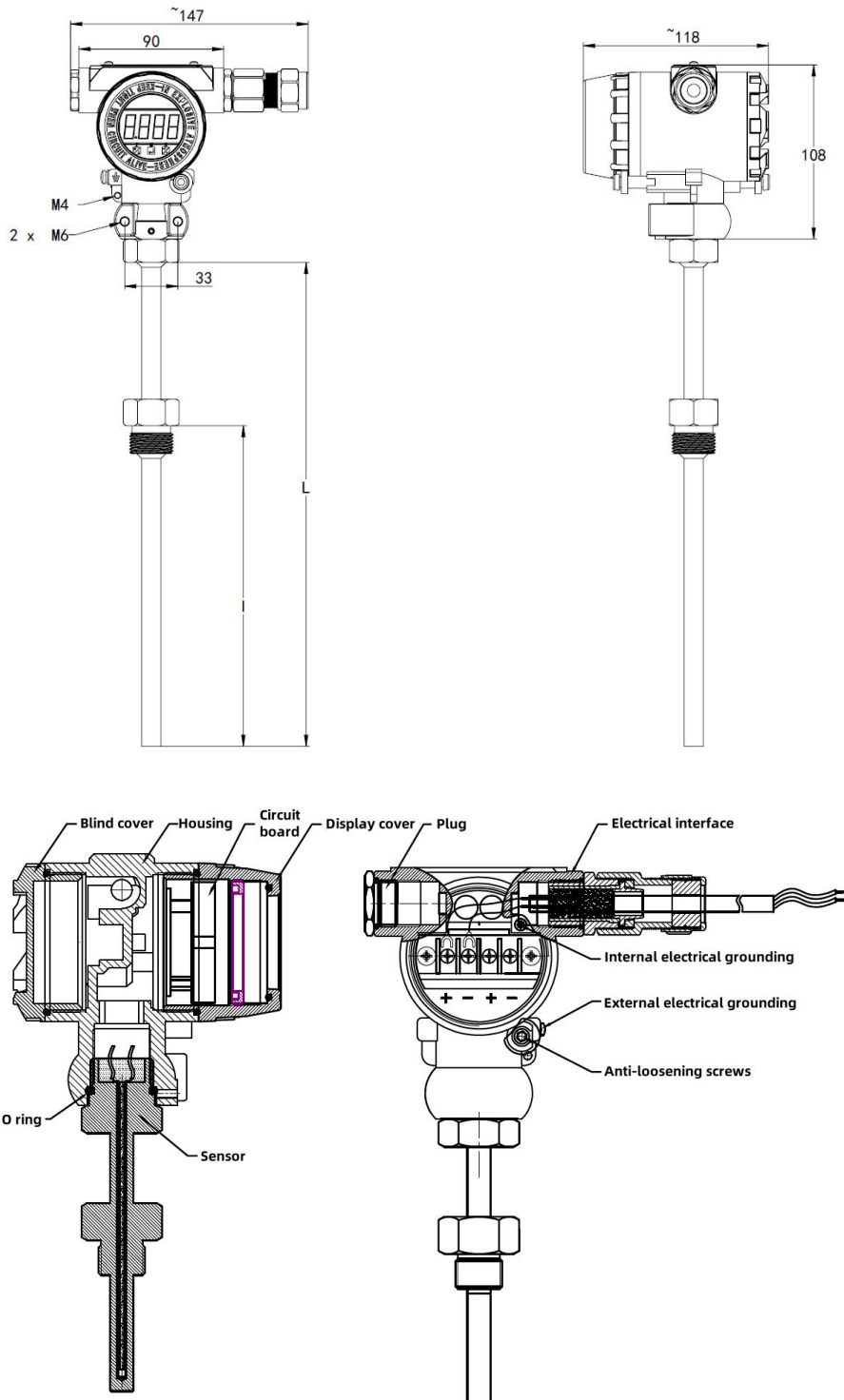

## Electrical Connection

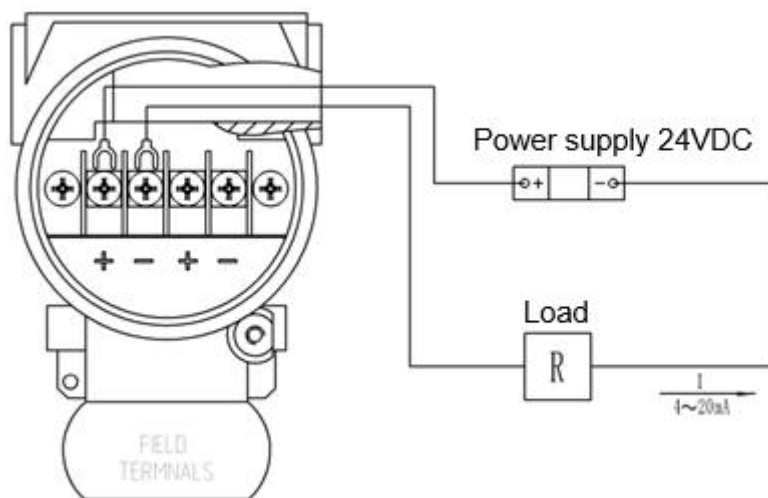

## On-site installation

- ◆ This product adopts thread installation, the typical thread is M20X1.5, and G1/2, M27X2 and other threads are optional; in addition, there are chuck, flange and other installation methods available.
- ◆ Check the explosion-proof housing cover before installation to ensure that it is tightened;
- ◆ Use a wrench to clamp it on the hexagon of the transmitter during installation. It is best to connect it to the measuring pipeline through a valve. The internal and external grounding screws must be reliably grounded.
- ◆ After the cable is connected to the terminal, the anti-loosening workpieces at both ends of the front and rear covers are tilted at a certain angle, and the anti-loosening screws are tightened. When the product is installed and used, the free end of the cable should be connected to an explosion-proof device that is suitable for the environment.

## Precautions for Explosion-proof Model Usage

- ◆ The transmitter housing should be reliably grounded when in use;
- ◆ The operating environment temperature range of explosion-proof products is  $-40^{\circ}\text{C} \sim +60^{\circ}\text{C}$ ;
- ◆ When using explosion-proof products on site, the principle of "opening the cover after power off" must be followed during maintenance;
- ◆ Users are not allowed to replace the product's electrical components and system connection status at will.
- ◆ The installation, use and maintenance of the product should also comply with the product instruction manual.

## Ordering Guide

Model	Type							
HTM208	HTM208 digital temperature transmitter							
	<b>Code</b>	<b>Installation</b>						
	LW-G	Threaded installation						
	FL-G	Flange installation						
	KP	Clamp installation						
	<b>Range</b>	<b>Measuring Range</b>						
	(0-X) °C	Fill X directly						
	<b>Code</b>	<b>Output signal</b>						
	B1	(4-20)mA						
	B7	RS485						
	B8	HART						
	<b>code</b>	<b>Installation form</b>						
	1	Fixed						
	2	Movable						
	<b>Code</b>	<b>Process Connection</b>						
	P1	M20×1.5						
	P4	G1/2						
	P17	M27×2						
	P22	M16×1.5						
	K1	1.5" clamp						
	K2	2" clamp						
	F20	DN20						
	F50	DN50						
	<b>Code</b>	<b>Electrical Connection</b>						
	C8	Cable gland NPT1/2" Female						
	<b>Code</b>	<b>Sensor type</b>						
	P	PT100						
	K	K index thermocouple						
	S	S index thermocouple						
	<b>Code</b>	<b>Others</b>						
	d	Exd IIC T6 Gb						
	f	Ex tb IIC T80°C Db						
	l	Insertion depth(mm)						
	L	L=Total length of protective tube(mm)						
	φ	φ=Protection tube diameter(mm)						
	F	Special anti-corrosion requirements						
HTM208	LW-G	(0-300) °C	B1	1	P1	C2	P	d I=200 L=350 φ=12

## Certification Information

Factory certification	
Certification organization	CQM
Quality management system	ISO 9001:2015
Certification scope	Research, development and manufacture of pressure transmitter and temperature transmitter
Certificate No.	00223Q21711R1S